



WBPA20180A

2 - 18 GHz 1/2 WATT WIDE BAND POWER AMPLIFIER

REV A
May 2024

Key Features



- 50 Ohm Impedance
- 2.0 ~ 22.0 GHz
- 3.0 dB Noise Figure
- 27.0 dBm Output P_{1dB}
- 27.0 dB Gain
- +/-1.0 dB Gain Flatness
- 2:1 VSWR
- Single Power Supply
- >34 years MTBF
- RoHS Compliant

Product Description

WBPA20180A is integrated with WanTcom proprietary power amplifier technology, high frequency micro electronic assembly techniques, and high reliability design to realize optimum output power, wideband, high linearity, and excellent gain flatness performances together. With single DC power operation, the amplifier has optimal input and output matching in the specified frequency range at 50-Ohm impedance system. The amplifier has standard field replaceable SMA connectorized WP-10 Gold plated housing.

The amplifier is designed to meet the rugged standard of MIL-STD-202g.

CAUTION:



ELECTROSTATIC DISCHARGE SENSITIVE

Applications

- Microwave Radio
- Satellite VSAT & DBS
- 802.16 & 802.20 WiMAX
- WLL & MMDS
- Test Instrument



Specifications

Additional heat sink is required!

Summary of the electrical specifications WBPA20180A at room temperature

Index	Testing Item	Symbol	Test Constraints	Min	Nom	Max	Unit
1	Gain	S ₂₁	2.0 – 18.0 GHz, extendable to 22 GHz		27		dB
2	Gain Variation	ΔG	2.0 – 18.0 GHz, extendable to 22 GHz		+/- 1.0		dB
3	Input VSWR	SWR ₁	2.0 – 18.0 GHz, extendable to 22 GHz		2:1	2.4:1	Ratio
4	Output VSWR	SWR ₂	2.0 – 18.0 GHz, extendable to 22 GHz		2:1	2.4:1	Ratio
5	Reverse Isolation	S ₁₂	2.0 – 18.0 GHz, extendable to 22 GHz		45		dB
6	Noise Figure	NF	2.0 – 6.0 GHz		3.5	5.0	dB
			6.0 – 18.0 GHz		2.5	4.0	
7	Output Power @ 1dB Compression	P _{1dB}	2.0 – 18.0 GHz		27		dBm
8	DC Current Consumption	I _{dd}	V _{dd} = +10 V		460		mA
9	DC Power Supply Voltage	V _{dd}		+9.5	+10	+10.5	V
10	Junction to Base Thermal Resistance	R _{th}	output stage, V _{ds} = 10V, I _{ds} = 400 mA			14.0	°C/W
11	Operating Temperature	T _o		-40		+85	°C
12	Maximum CW RF Input Power	P _{IN, MAX}	2.0 – 18.0 GHz			18	dBm

Absolute Maximum Ratings

Parameters	Unit	Ratings
DC Power Supply Voltage	V	-0.5 ~ +12.0
Drain Current	mA	500
Total Power Dissipation	W	5
CW RF Input Power	dBm	18
Junction Temperature	°C	150
Storage Temperature	°C	-55 ~ 125
Operating Temperature	°C	-40 ~ 85

Operation of this device above any one of these parameters may cause permanent damage.

Ordering Information

Model Number	WBPA20180A
--------------	------------

Functional Block Diagram

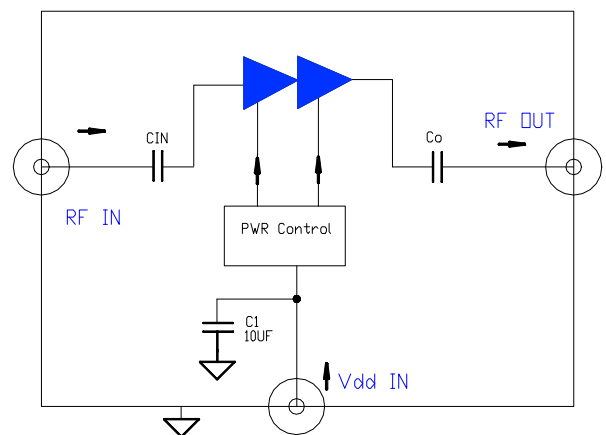

Specifications and information are subject to change without notice.



Typical Data

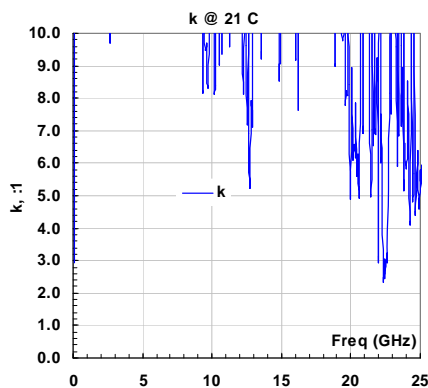
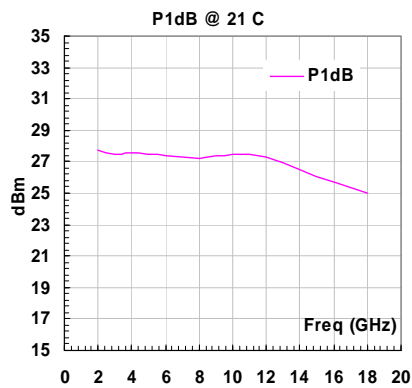
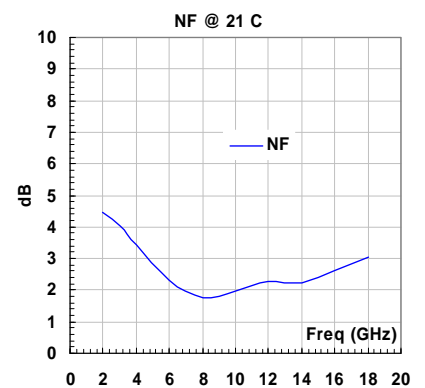
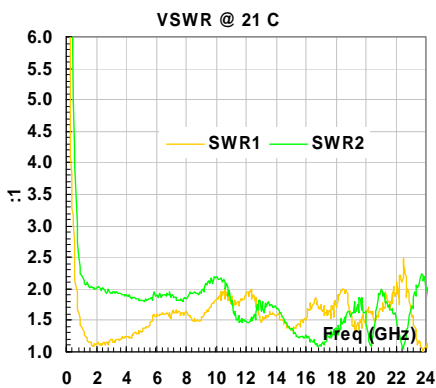
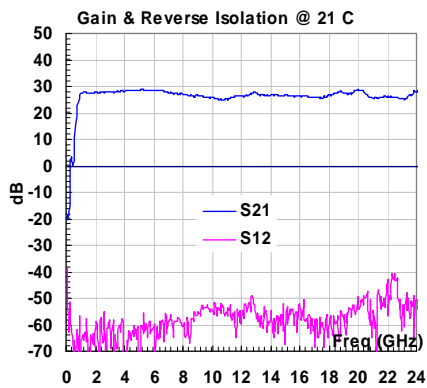

Specifications and information are subject to change without notice.



Outline, WP-10 Housing

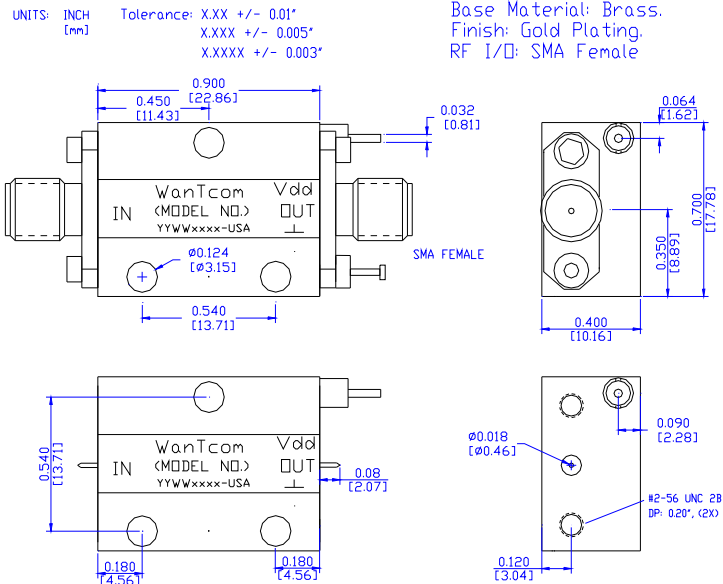

Application Notes:

A. SMA Torque Wrench Selection

Always use a torque wrench with 5 ~ 6 inch-lb coupling torque setting for mating the SMA cables to the amplifier. Never use torque more than 8 inch-lb wrench for tightening the mating cable to the connectors. Otherwise, the permanent damage will occur to the SMA connectors of the amplifier. 8710-1582 (5 inch-lb) is one of the ideal torque wrench choice from Agilent Technology.

B. DC Power Line Connection

Strip the insulation layer at the end of DC power supply wire. The stripped length should be around 0.100" to 0.200". The 24 ~ 26 American Wire Gauge wire is suitable. Wound the stripped wire about 3/4 to 1 turn on the DC feed thru center pin. Solder the wounded wire and the center pin together. Clean the soldering joint by a Q-tip with alcohol to remove the flux and residue.

Do not use large soldering iron tip with more than 750 degree Fahrenheit to solder the wire and feed thru pin. Damage may occur to the feed thru. 0.010" size tip with 750 degree Fahrenheit temperature setting is suitable for the soldering works.

Repeat the process to solder the DC return wire on the ground turret. Higher temperature and larger tip can be used for this ground soldering.

C. Mounting the Amplifier

Use three pieces of #4-40 with longer than 9/16" screws for mounting the amplifier on a metal-based chase. Flat and spring washers are needed to prevent the screw loosening during the shock and vibration. Always use the appropriate torque setting of the power screwdriver to mount them.

High thermal conductivity thermal film such as T-gon is needed between the bottom of the PA and the heat sink surface. In order to work at 85 °C ambient temperature, a heat sink with the maximum thermal resistance of 2.25 °C/W is recommended. Refer to AN-155 for heat sink design, http://wantcominc.com/engineering_tools.htm.
