



**SIGNAL  
MICROWAVE**



**Connector Products February 2020**

## Edge Launch Key Features:

- No Soldering Required
- Top Ground Only
- Board Design Support Available
- Test Boards Available

## Edge Launch Connectors

### ELF110 1.0 mm (110 GHz) Edge Launch Connectors

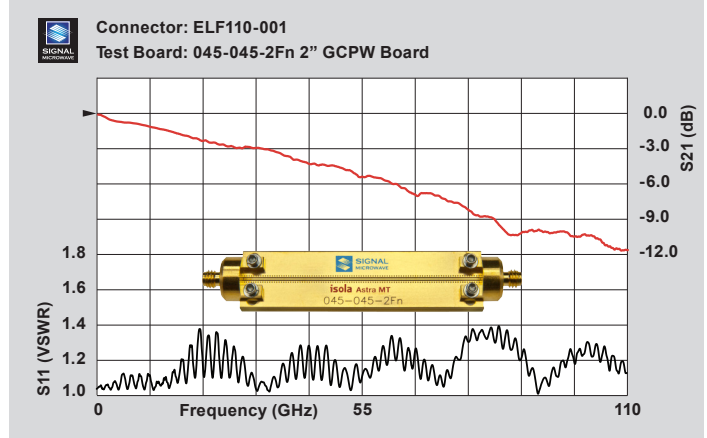
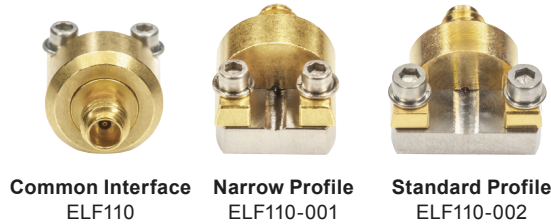

### ELF67 1.85 mm (67 GHz) Edge Launch Connectors

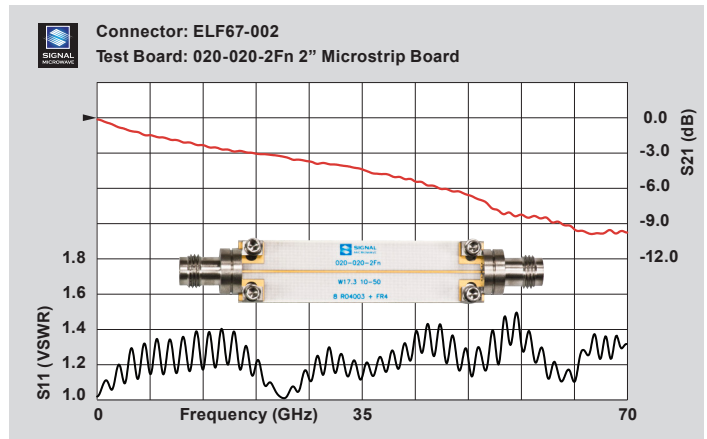

### ELF50 2.40 mm (50 GHz) Edge Launch Connectors

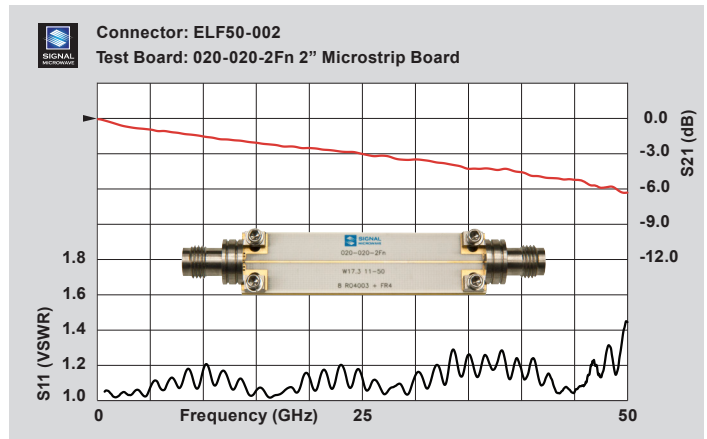

# Signal Microwave

## ELF40 2.92 mm (40 GHz) Edge Launch Connectors

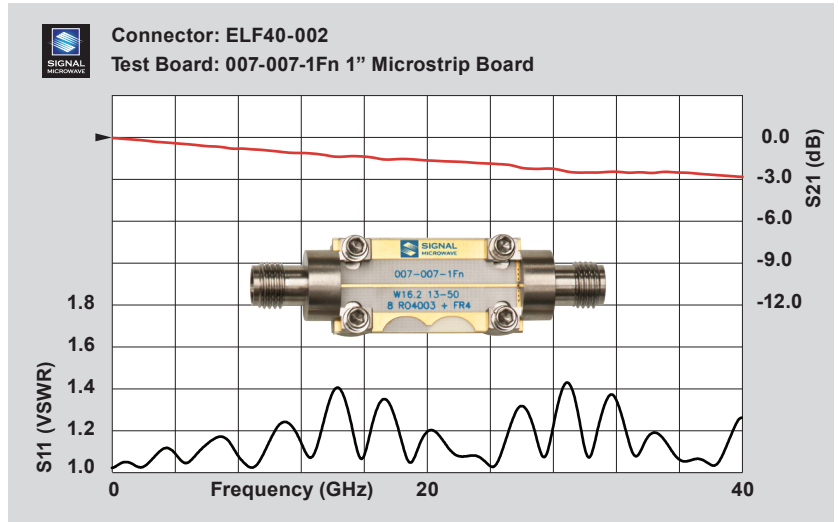

1" microstrip test board with typical data through 40 GHz

## NEW PRODUCT

### Edge Launch Drop-in Replacement Connectors

## ELFT40 2.92 mm (40 GHz)

- 2.92 mm Interface
- 1.15:1 VSWR max
- Top Ground Only
- 40 GHz Bandwidth
- Board Design Support Available
- Test Boards Available
- Samples with Data Available
- No Soldering Required
- Optimized for 5-10 mil Substrate

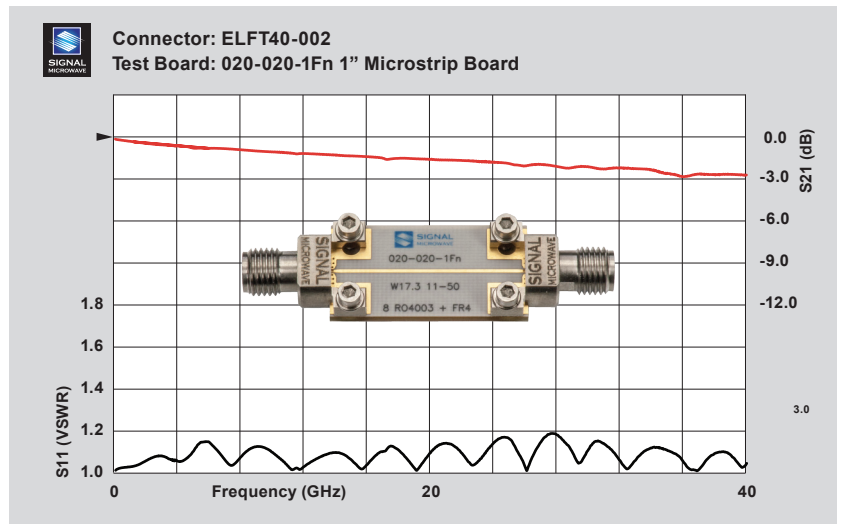

1" microstrip test board with typical data through 40 GHz

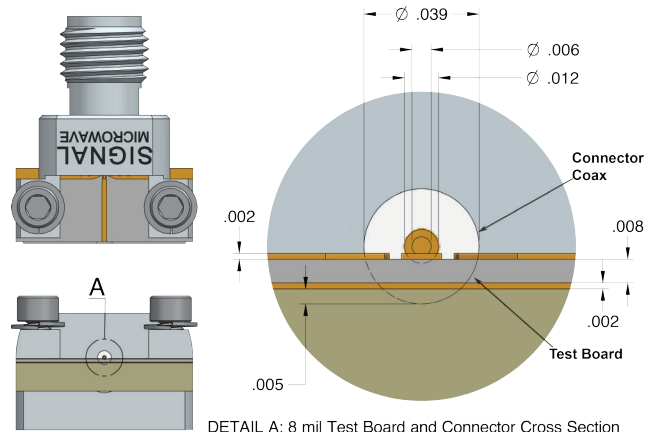
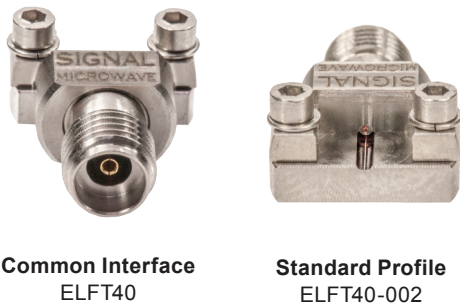

# Signal Microwave

## Test Boards for Edge Launch Connectors

(70 GHz)

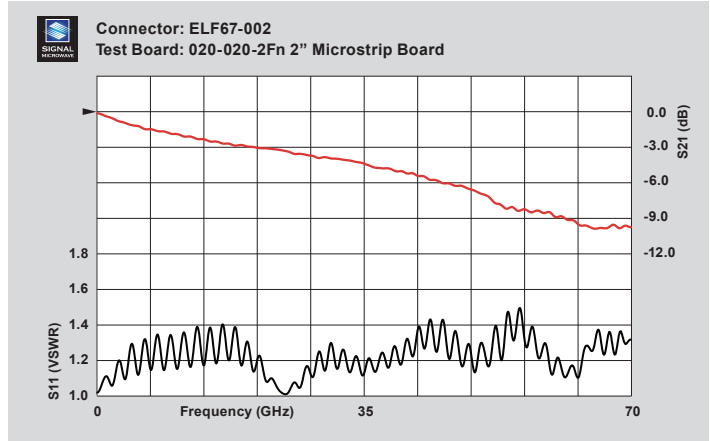
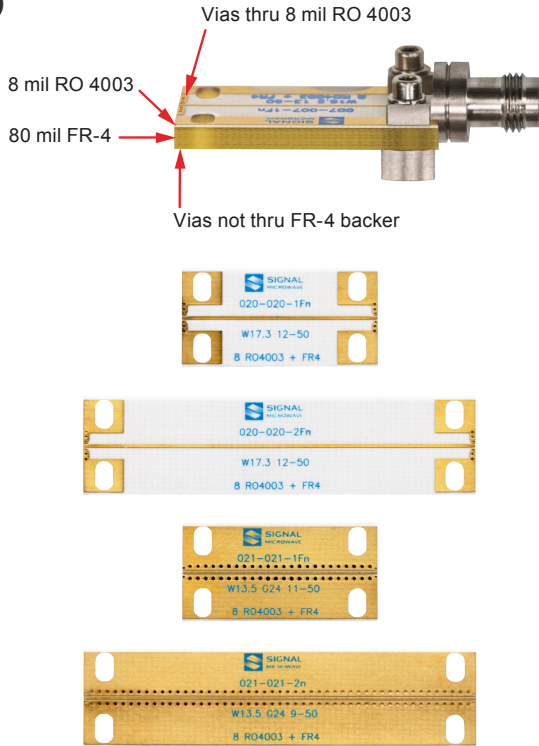

### 70 GHz Test Board Part Numbers:

- 020-020-1Fn** 1" Microstrip
- 020-020-2Fn** 2" Microstrip
- 021-021-1Fn** 1" Grounded Coplanar Waveguide (GCPW)
- 021-021-2Fn** 2" Grounded Coplanar Waveguide (GCPW)

## Test Boards for Edge Launch Connectors

(110 GHz)

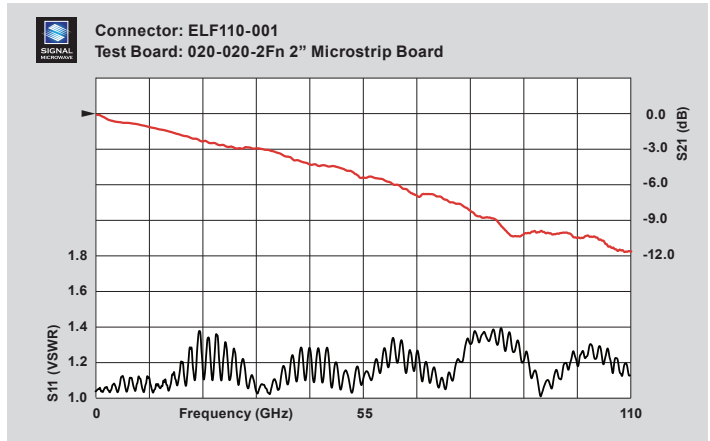
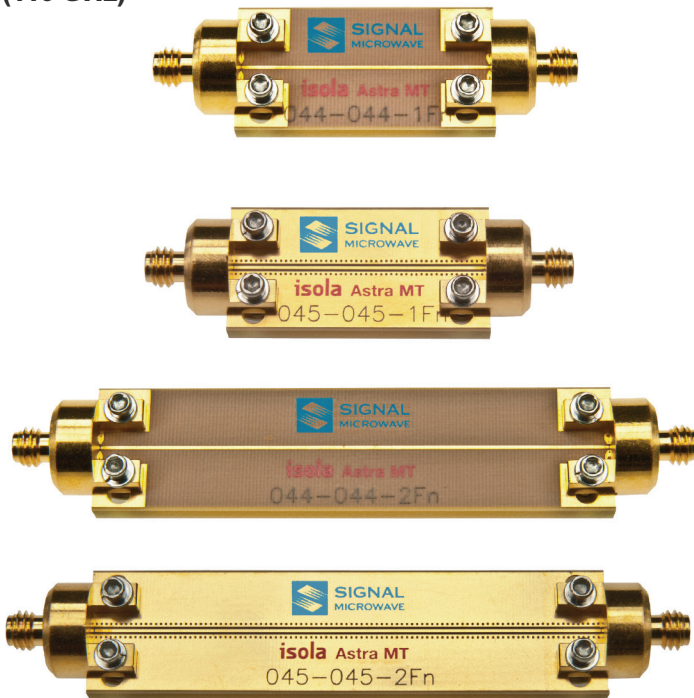

### 110 GHz Test Board Part Numbers:

- 044-044-1Fn** 1" Microstrip
- 044-044-2Fn** 2" Microstrip
- 045-045-1Fn** 1" Grounded Coplanar Waveguide (GCPW)
- 045-045-2Fn** 2" Grounded Coplanar Waveguide (GCPW)

All test board designs are available to customers at no charge in .pdf and .dxf formats.  
Demo boards are also available with sample connectors and test data.



# Signal Microwave

## Top Launch Connectors

### TLF40 2.92 mm (40 GHz)

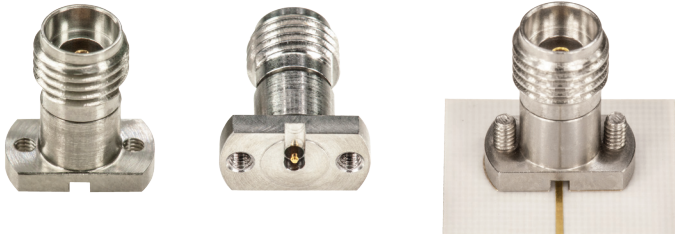

- Edge Launch Type Performance Anywhere on the Board
- 2.92 mm Connector for high speed digital industry with superior electrical performance
- Compression fit, screw-on mounting, does not require soldering

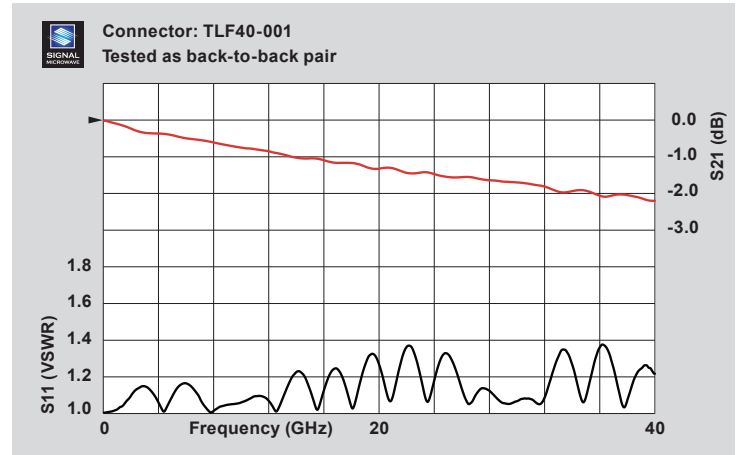

1" microstrip test board with typical data through 40 GHz

## Test Boards for Top Launch Connectors (40 GHz)

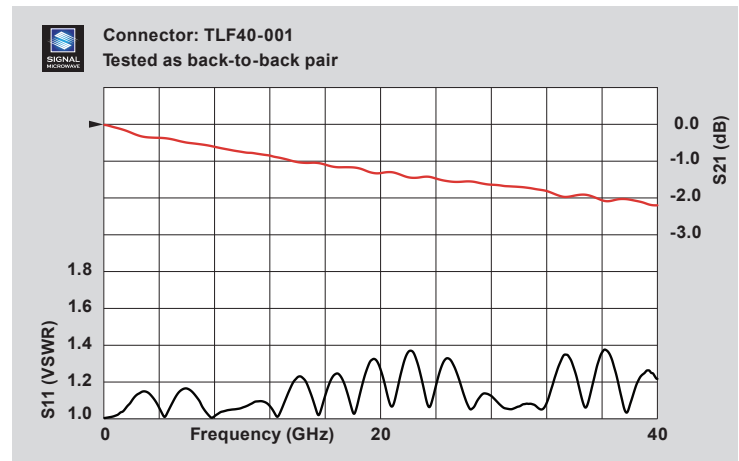
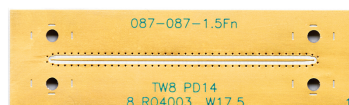
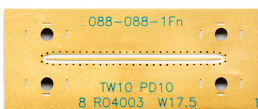
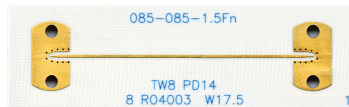
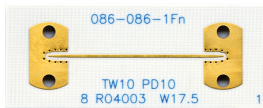
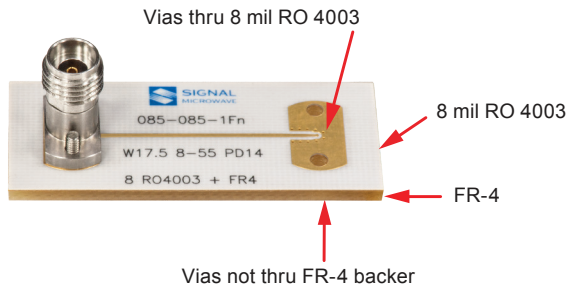

### 40 GHz Test Board Part Numbers:

- 086-086-1Fn** 1" Microstrip
- 085-085-1.5Fn** 1.5" Microstrip
- 088-088-1Fn** 1" Grounded Coplanar Waveguide (GCPW)
- 087-087-1.5Fn** 1.5" Grounded Coplanar Waveguide (GCPW)

# Signal Microwave

## Field Replaceable Connectors

### FRF40 2.92 mm (40 GHz)

- 2.92 mm Interface
- Standard 2 & 4 Hole Flanges
- 40 GHz Bandwidth
- Rear Socket for 12 mil pin
- Low VSWR:  
DC–27.0 GHz.....1.10:1  
27.0–40.0 GHz....1.15:1
- Temp Range -55° to +105°

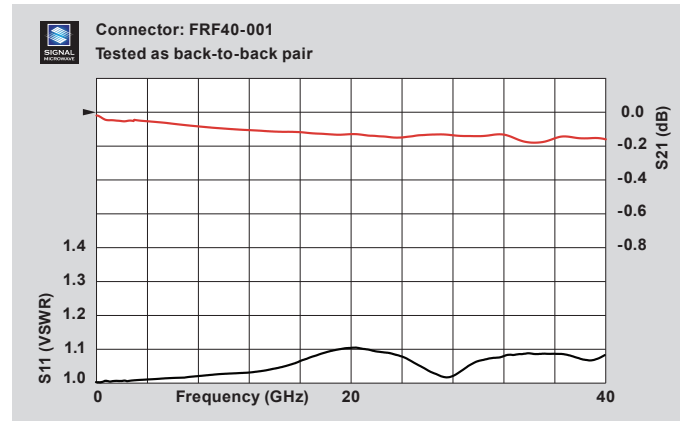
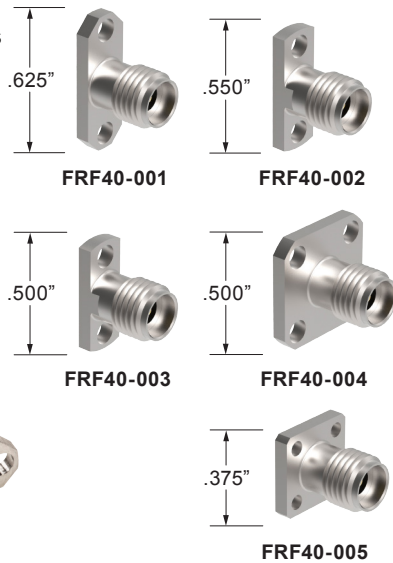

Typical test data through 40 GHz using FRF40-001 back-to-back connector pair with test pin.

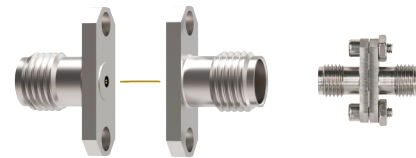

## Vertical Launch Connectors

### VLF40 2.92 mm (40 GHz)

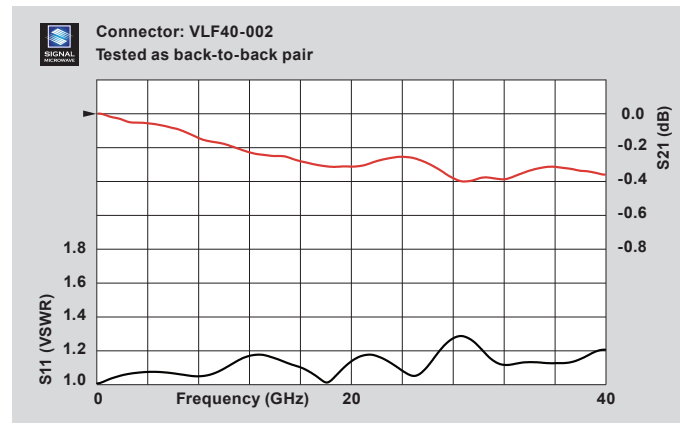
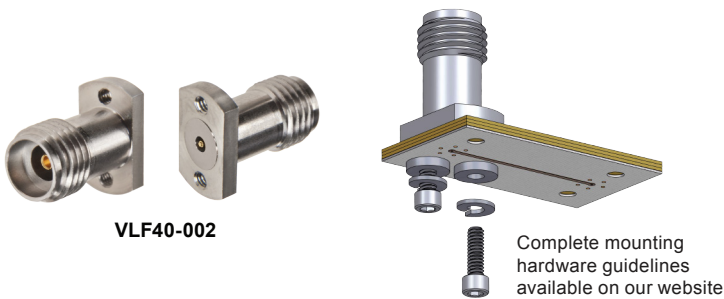

Typical data for 2 connectors tested as a back-to-back pair



- 2.92 mm Connector for high speed digital industry with superior electrical performance
- Compression fit, screw-on mounting, does not require soldering

# Signal Microwave

## Plug and Play De-embedding Kit in Support of IEEE-P370

Our library of innovative designs led to this kit which includes 70 GHz test boards, 2.92 mm or 1.85 mm connectors, and a flush short, all using our own designed and manufactured boards and connectors. At DesignCon a paper, "A NIST Traceable PCB Kit..." will be presented by members of the committee which describes the use of this kit.

### Five Board Types

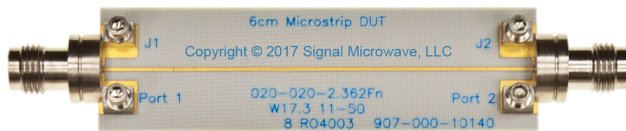

#### 1 6 cm DUT Microstrip

The de-embedded kit takes a known DUT which can be directly measured and the results saved. The data for the DUT is established at NIST traceable reference planes and therefore is repeatable.

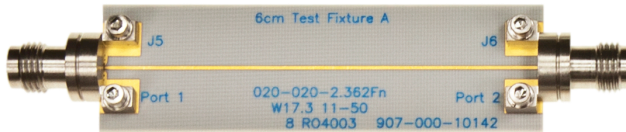

#### 2 6 cm Test Fixture

A set of 2 test fixtures with good performance can be measured and de-embedding files created. The de-embedding algorithm is applied and the resultant DUT data can be compared to the directly measured DUT data.

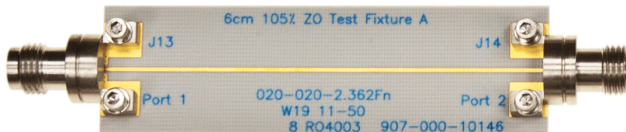

#### 3 6 cm 105% Z0 Test Fixture

A degraded set of fixtures with 105% impedance is also included to challenge the de-embedding algorithm.

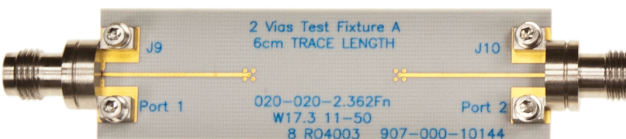

#### 4 2 Vias Test Fixture

A third set of fixtures with the microstrip line starting on top of the board then transitioning to the bottom of the board and back on top again is included. These will further challenge the de-embedding algorithm.

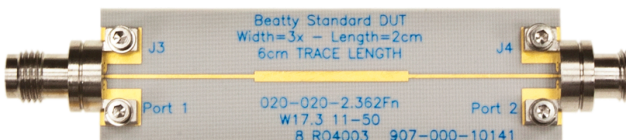

#### 5 Beatty Standard DUT

A "Beatty" standard line of 50 ohm /25 ohm /50 ohm impedance is also available as a DUT and can be used to verify TDR measurement de-embedding.



# Signal Microwave

## Calibration Boards

### Turnkey 0402 Package Test System with 40 GHz TRL/LRL Calibration and DUT Boards

This kit provides a total test fixture solution by providing both the TRL/LRL calibration board to calibrate the VNA to remove the connectors and 4 inches of the PCB trace from the measurement. Each test fixture contains 2.92 mm connectors on each end and a solder point for the SMD component for accurate measurements.

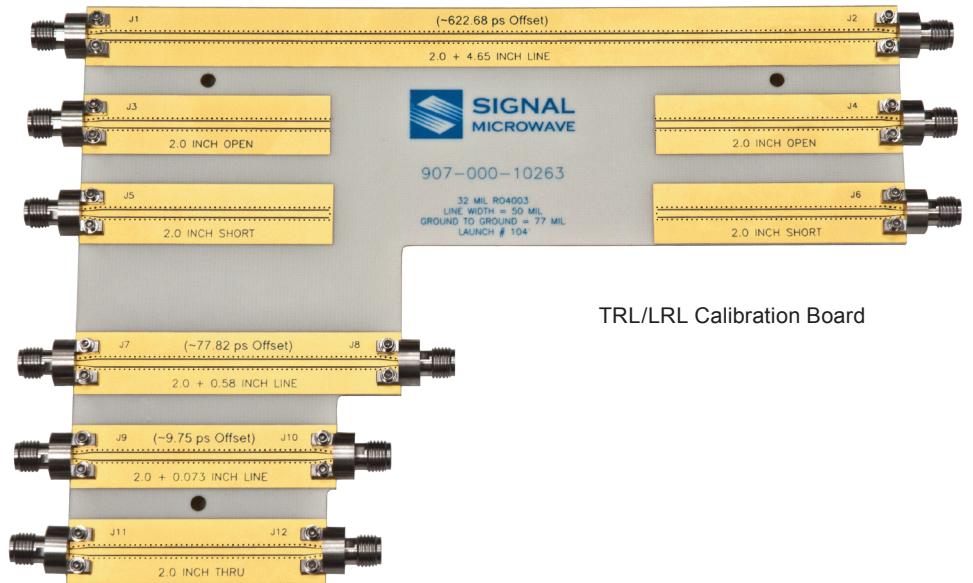
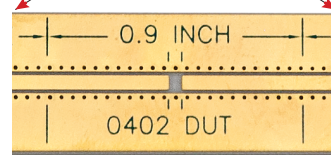
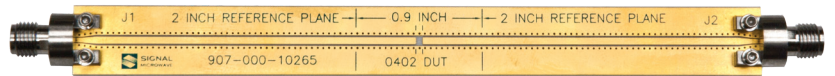

TRL/LRL Calibration Board

## Other Boards (40 GHz and 70 GHz)

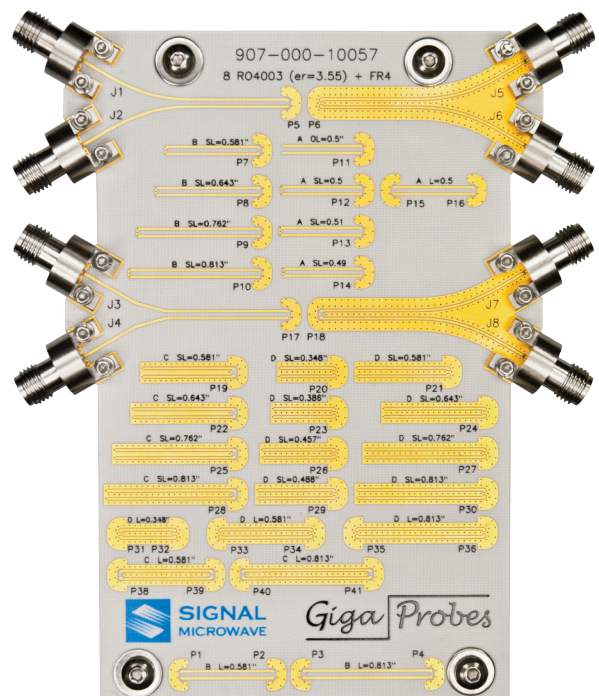
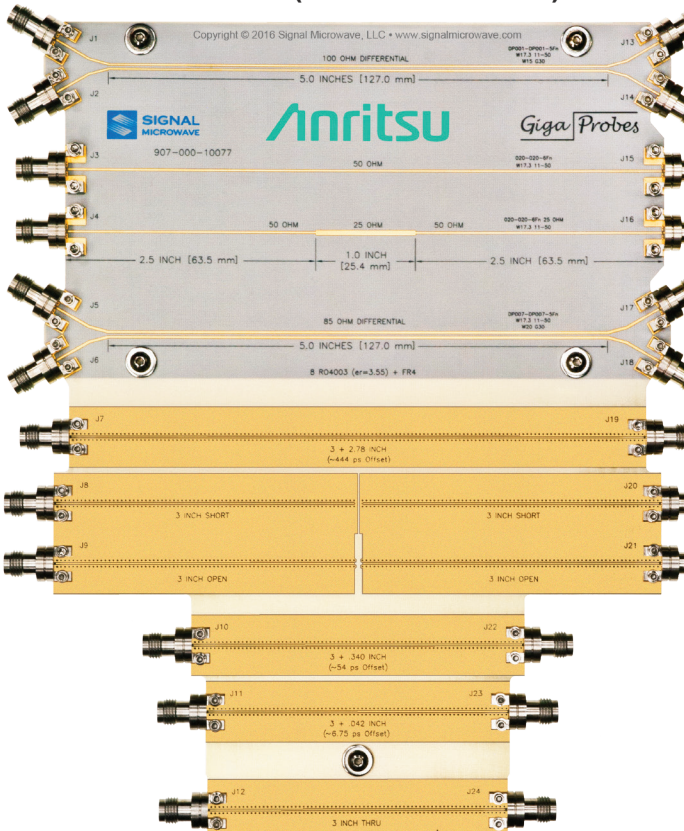

Part No. 907-xxx-10077

Part No. 907-xxx-10057



# Signal Microwave

## Broadband Test Verification Boards (40 GHz and 70 GHz)

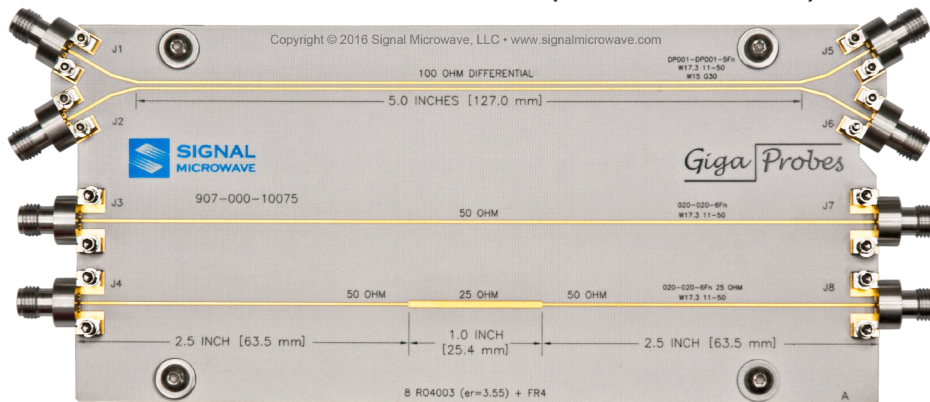

**DB40-002 Probe Verification Board**

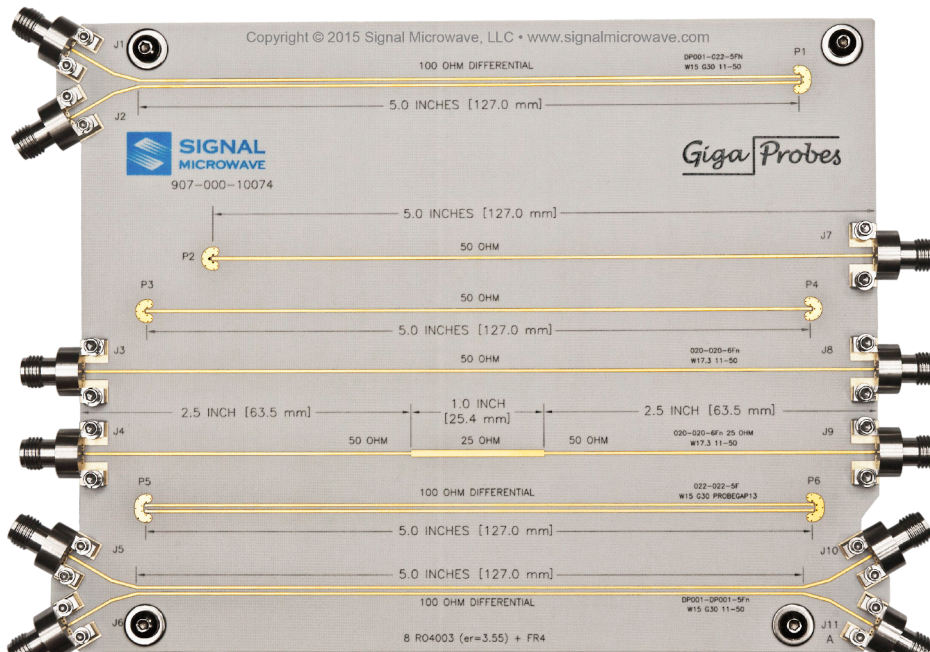

**DB40-003 Basic Verification Board**

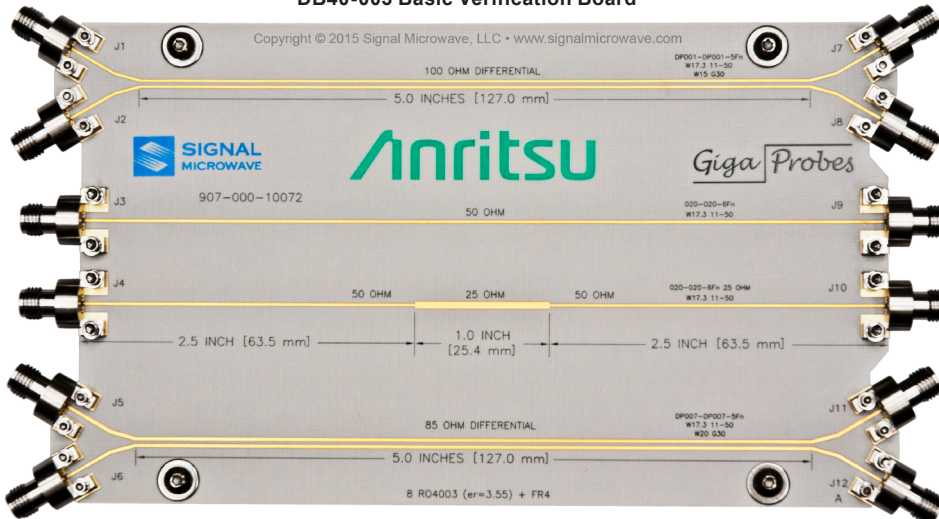

**907-040-10072 Anritsu Verification Board**

“xxx” is a placeholder to define frequency range depending on connector types.

# Signal Microwave

## Connector Nomenclature

### 2.92mm Interface

### 1.85mm Interface

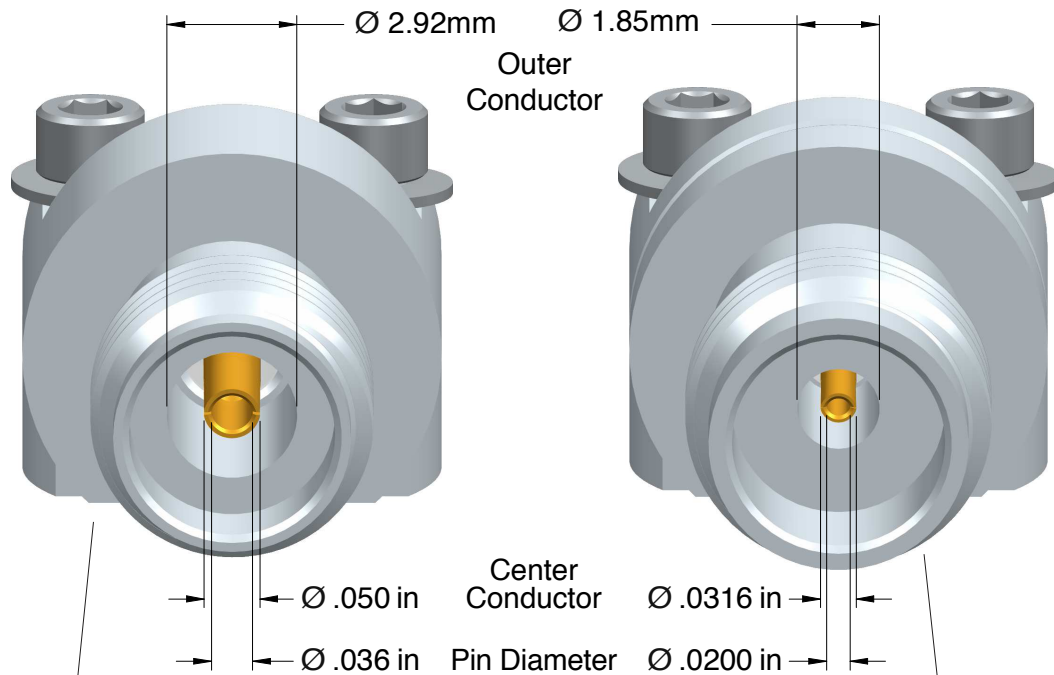

## Connector Compatibility

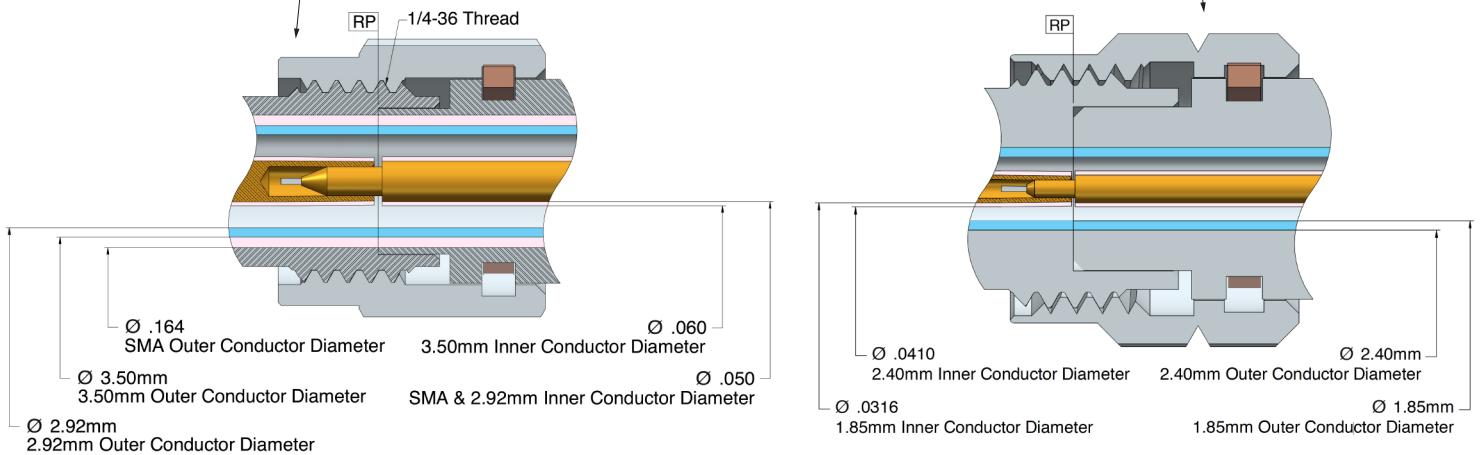

### SMA / 3.5mm / 2.92mm

- SMA interface connectors (18/27 GHz bandwidth)
- 3.5mm interface connectors (33 GHz bandwidth)
- 2.92mm interface connectors (40 GHz bandwidth)
- All of these connectors are compatible with each other

### 2.40mm / 1.85mm

- 2.40mm interface connectors (50 GHz bandwidth)
- 1.85mm interface connectors (70 GHz bandwidth)
- All of these connectors are compatible with each other



# Signal Microwave

Cutaway Side View of a Mated Connector Pair

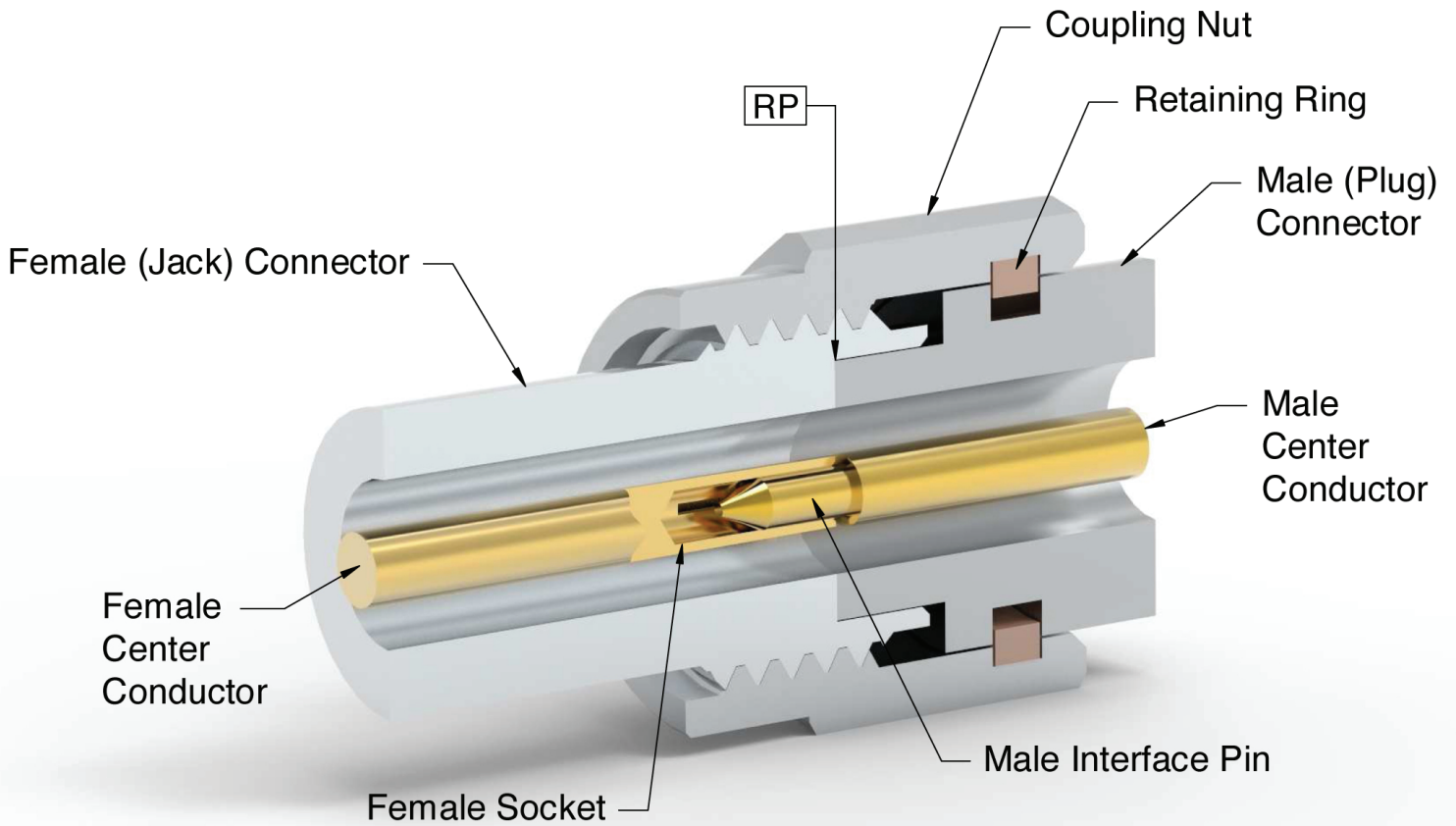
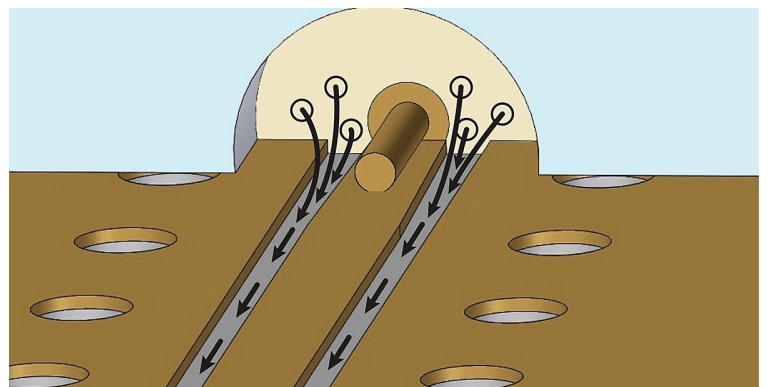
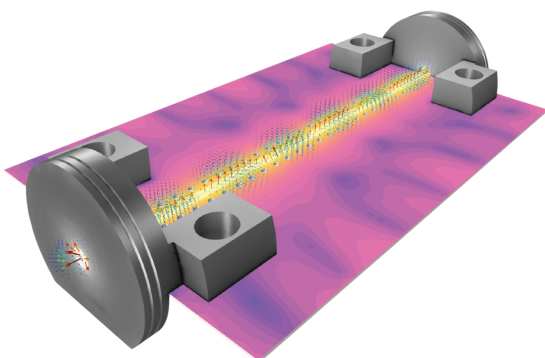

Image made using COMSOL Multiphysics® software and provided courtesy of COMSOL.

## PCB Design Resources for Board Mount Connectors

- 3D models for simulation are available at no charge to help customers in their own development efforts.
- “Transparent Connections for 5G and WiGig Testing” that describes using 3D modeling tools to design board launches.



## TABLE OF CONTENTS

### **Connectors**

ELF110	2
ELF67	2
ELF50	2
ELF40	3
ELFT40	3
TLF40	5
VLF40	6
FRF40	6

### **Boards**

Test Boards	4-5
Plug & Play De-embedding Kit	7
Turnkey 0402 Package Test System	8
Calibration Boards	8
Broadband Test Verification Boards	9

### **Connector Education**

Connector Nomenclature	10
Connector Compatibility	10
Connector Cutaway Side View	11
Board Design	11

---

## NEW PRODUCTS

**ELFT40**



1.15:1 VSWR Thru 40 GHz

**PROBES**



70 GHz 100 Ohm True Differential

### **Signal Microwave, LLC**

Tempe, Arizona  
info@signalmicrowave.com  
www.signalmicrowave.com  
(480) 322-4992      022020

All Text and Images are Copyright © 2012–2020 Signal Microwave, LLC

